



Green Human Resource Management Practices and Environmental Performance: The Mediating Effect of Organizational Culture

Ademola Samuel Sajuyigbe^{1*} | Adebajji W. Ayeni² | Henry E. Inegbedion³ | Oghenechuko Salome Ighomereho⁴ | Adeshola Peter⁵

1. Corresponding Author, Department of Business Administration, Faculty of Social and Management Science, Precious Cornerstone University, Ibadan, Nigeria E-mail: sajuyigbeademola@yahoo.com
2. Department of Business Administration, Faculty of Social and Management Sciences, Bowen University, Iwo, Nigeria. E-mail: henry.inegbedion@bowen.edu.ng
3. Department of Business Studies, College of Faculty of Business and Social Sciences, Landmark University, Omu-Aran, Nigeria. E-mail: ayeni.banji@lmu.edu.ng
4. Department of Business Administration and Marketing, Faculty of Management Sciences, Redeemer's University, Ede, Nigeria. E-mail: ighomerehoo@run.edu.ng
5. Department of Business Studies, College of Faculty of Business and Social Sciences, Landmark University, Omu-Aran, Nigeria. E-mail: Peter.adeshola@lmu.edu.ng

ARTICLE INFO

Article type:
Research Article

Article History:
Received 21 May 2022
Revised 26 January 2024
Accepted 18 February 2024
Published Online 18 September 2024

Keywords:
Green HRM,
Organizational Culture,
Green Environment,
Performance.

ABSTRACT

The study investigates the mediating effect of organizational culture (OC) on the relationship between green human resource management (GHRM) practices and environmental performance (EP). A survey was conducted of 323 manufacturing industry employees in selected food and beverage companies in Southwest Nigeria. The factor loadings of the constructs are above 0.70, indicating that the elements of the construct are valid. The data were collected using a 5-point Likert scale questionnaire. Structural equation modeling (SEM) was employed to analyze the data using STATA version 15. The findings showed that EP is positively related to GHRM practices (green recruitment and selection, green career development, green performance appraisal, green reward system, and green participation) and OC. However, the relationship between EP and green recruitment and selection, green career development, and OC were significant while the relationship between EP and green performance appraisal, green reward system, and green participation was not significant. Furthermore, the mediating effect of OC reveals that OC mediates the relationship between the green reward system, green recruitment and selection, and EP but does not mediate the relationship between green career development, green performance appraisal, green participation, and EP. The mediating role of OC in terms of green recruitment and selection as well as the green reward system will help to reduce environmental threats.

Cite this article: Sajuyigbe, A.S.; Ayeni, A.W.; Inegbedion, H. E.; Ighomereho, S.O. & Peter, A.O. (2024). Green Human Resource Management Practices and Environmental Performance: The Mediating Effect of Organizational Culture. *Interdisciplinary Journal of Management Studies (IJMS)*, 17 (4), 1155-1172. DOI: <http://doi.org/10.22059/ijms.2024.343182.675108>



© Ademola Samuel Sajuyigbe, Adebajji W. Ayeni, Henry E. Inegbedion, Oghenechuko Salome Ighomereho, Adeshola Peter **Publisher:** University of Tehran Press.
DOI: <http://doi.org/10.22059/ijms.2024.343182.675108>

Introduction

In recent years, environmental sustainability has garnered increased attention from industry practitioners and policymakers. Both the United Nations and former President, Ban Ki-Moon, have urged investors to support climate change initiatives to address global environmental challenges (UNEP, 2020). This has prompted stakeholders to press organizations for involvement in ecological innovation, waste reduction and recycling, toxic chemical emission reduction, and electric energy consumption reduction. Simultaneously, there is a call for enhanced utilization of renewable energy and sustainable fuels while maintaining product quality (Kuo et al., 2022; Stojanoska, 2016). Recognizing the global significance of organizational environmental sustainability, Nigerian manufacturers are proactively devising environmentally friendly strategies. Among these strategies, green human resource management (GHRM) (Herman et al., 2021) and organizational culture (Ren et al., 2018) play pivotal roles. According to Zhang et al. (2019), GHRM, being multifaceted, is acknowledged as a managerial tool influencing employees' environmentally friendly behavior and environmental performance (EP) (Aftab et al., 2023; Masri, 2016). The evidence suggests that GHRM practices, encompassing green recruitment and selection, green career development, green performance appraisal, green reward systems, and green participation, can minimize the carbon footprint and sustain organizational behavior (Mandago, 2019). Consequently, one of the objectives of this study is to examine the influence of GHRM practices on EP in the context of Nigeria.

Organizational environmental culture is another recognized construct playing a vital role in the shift toward sustainability and EP, according to environmentalists, scholars, and researchers (Adebayo et al., 2020). It represents shared values, assumptions, norms, and traditions guiding individuals in understanding how organizations work toward environmental sustainability (Shafaei et al., 2020). Existing literature posits that organizational environmental culture serves as a platform for achieving environmental sustainability by influencing thoughts, feelings, and interactions through GHRM (Afum et al., 2020; Fatoki, 2019). Numerous studies establish a positive association between organizational culture and EP, including waste reduction, emissions reduction, electric energy consumption reduction, improved use of renewable energy, sustainable fuels, and enhanced product quality. This study investigates the mediating effect of organizational culture on the relationship between GHRM practices and EP. Therefore, another objective of this research is to demonstrate the mediating role of organizational culture between GHRM practices and EP. It is essential to highlight the importance of mediation analysis, as limited interest or awareness could lead to its omission from research study designs, potentially hindering a comprehensive understanding of underlying mechanisms.

Moreover, numerous studies have associated various theories with Environmental Performance (EP), including the Resource-Based View (RBV) theory (Magsi et al., 2018; Tajeddini et al., 2020), Moral Foundations Theory (MFT) (Tezel & Giritli, 2019), Institutional Theory (Shafaei et al., 2020), Ability, Motivation, and Opportunity (AMO) (Mwita, 2019), Theory of Planned Behavior (TPB) (Safari et al., 2018), Linking Instrumental Theory (Oyewale, 2019), and Value Belief Norms Theory (VBNT) (Vanderploeg & Lee, 2019). In the realm of theory, GHRM is tasked with the development of green recruitment and selection, green training and development, green performance evaluation, and green reward programs. This study fills a gap in the literature by employing a combination of three theories (Resource-Based View theory, Ability, Motivation, and Opportunity, and Moral Foundations Theory) to elucidate the mediating role of Organizational Culture (OC) in the connection between GHRM practices and EP. Consequently, researchers face essential questions: What is the direct impact of GHRM practices on EP, and to what extent do GHRM practices indirectly influence EP through the mediation of OC?

Literature Review

Theoretical Framework

Resource-Based View Theory (RBV)

The foundation of the Resource-Based View (RBV) can be traced back to the works of Barney (1986) and Dierickx and Cool (1989), who contend that a relationship exists between a firm's resources (such as employees and systems) and the attainment of sustained competitive advantages. In alignment with this perspective, Wright et al. (2001) emphasize that human resources represent a crucial asset for firms to gain sustainable competitive advantages. Previous research corroborates that the Resource-

Based View identifies human resources as a key source of sustainable competitive advantage, enhancing the Environmental Performance (EP) of a firm (Magsi et al., 2018). Similarly, Schmit et al. (2012) assert that human resources play a vital role in a firm's ability to secure a sustainable competitive advantage. Furthermore, Barney (2001) underscores that the effective management of resources and skills is essential for an organization's sustainable competitiveness, emphasizing the importance of not just possessing resources but also managing them strategically.

Therefore, according to the Resource-Based View, green recruitment and selection, green training and development, green performance appraisal, and green reward systems are effective tools for enhancing EP. In support of this perspective, Saifulina and Carballo-Penel (2017) provide evidence that green Human Resource Management (HRM) practices foster employee engagement in ecological innovation, contribute to the reduction of waste and recycling, mitigate the emissions of toxic chemicals, decrease the consumption of electricity, promote the use of renewable energy and sustainable fuels, and enhance product quality.

Ability, Motivation and Opportunity (AMO)

Ability, Motivation, and Opportunity (AMO) theory is another popular theory that links HRM to EP. The theory was conceptualized by Appelbaum et al. (2000) to identify the best HRM practices that foster organizational performance. The theory posits that individual performance is a function of employees' ability, motivation, and opportunities to perform. Renwick et al. (2013) link the three core dimensions of AMO theory to the GHRM that influences EP. According to the authors, the first core dimension of AMO theory develops green knowledge in employees through green selection and recruiting, and green training. The second core dimension is to motivate employees through green appraisal and green rewards. The third core dimension is to stimulate employee participation through green employee empowerment strategies. In another study, Mwita (2019) argues that for an organization to achieve its EP, efforts should be made to boost the employees' ability and motivation, and opportunities should be given to them to participate in decision-making. Therefore, AMO theory suggests that EP such as the reduction in waste, reduction in consumption of electricity, high productivity, increase in product quality and revenue generation may be achieved if employees acquire the right green knowledge and skills, (ability), are induced by both monetary and non-monetary rewards to adopt GHRM (motivation) and, are permitted to engage in and use their green knowledge and skills in the decision-making process (Renwick et al., 2013).

Moral Foundations Theory (MFT)

Moral Foundations Theory (MFT) was recently adopted by researchers to link the moral passions of the environmental movement to environmental sustainability and performance. The theory of moral foundations developed by Haidt and Joseph (2004) and Graham et al. (2011) to explain the five components of moral foundations, namely care/harm, fairness/reciprocity, betrayal /loyalty, authority/respect, and sanctity/degradation. They discovered that morality is not just about what people think but also about what people feel when confronted with an experience. Thus, the MFT is premised on the assumption that morality is a system that builds from socio-cultural constructs and individuals' reasoning within the culture (Graham et al., 2011). Similarly, Martinelli (2013) argues that the green behavior of employees is associated with individual characteristics such as beliefs, norms and values, and socio-demographics. Two of the five moral dimensions, harm/care, and purity/sanctity, are the focus of this study because the care and sanctity foundation inspire some of the moral passions of the environmental movement, while pollution and industrialization degrade the purity of nature. Haidt and Graham (2007) posited that the assumption that people are naturally protected from harm has a connection to harm/care. In this regard, the desire to eradicate harm is the decision that is associated with a green environment. The purity/sanctity foundation is associated with the strong human emotion of disgust often related to degradation, the use of unsafe chemicals, acid drainage, the loss of biodiversity; intensive water use, pollution from poorly disposed waste, dirt, and airborne pollution, and alcohol abuse (Fawehinmi et al, 2020). Therefore, moral passion for the green environment among employees is the only way forward to environmental sustainability and performance.

Green Human Resource Management and Environmental Performance

Green HRM is a multifaceted approach to green management in which HRM is integrated into environmental management (Zhang et al., 2019). Green HRM has been recognized as a managerial tool that influences employees' environmentally friendly behavior and EP (Stojanoska, 2016). There is a growing number of empirical research evidence indicating that GHRM practices can improve EP and sustain organizational behavior by minimizing carbon footprint through green recruitment and selection, green career development, green performance appraisal, green reward system, and green participation (Mandago, 2019; Mwita, 2019; Zhang et al., 2019). The study of Shaban (2019) establishes that GHRM and its application practices have a significant effect on sustainability and EP. Another study conducted in Bangladesh by Al-Mamun (2019) confirms that GHRM is an alternative paradigm of sustainable development and EP. Similarly, the study of Pham et al. (2019) also reaffirms that GHRM practices are the impetus for EP. Empirical studies conducted by Mwita (2019), and Ullah (2017) reveal that GHRM is a tool for greening the environment.

The theoretical and empirical review imply that GHRM practices can improve EP and sustain organizational behavior by minimizing carbon footprint through green recruitment and selection, green career development, green performance appraisal, green reward system, and green participation. However, there is a need to identify the GHRM practices that influence EP, especially in a developing economy.

Green recruitment and selection, and Environmental Performance

Green recruitment and selection involve emphasizing environmental issues during recruitment and selection (Mandago, 2019). A company practices green recruitment and selection when environmental knowledge is required in placing a job advertisement, interviewing applicants, selecting candidates to fill a vacant position, and when the company asks about an employee-related environmental issue. In the study of Mwita (2019) a linear relationship was found between green recruitment, selection, and performance. Similarly, Martins et al (2021) found that green recruitment has a positive and significant impact on environmental performance, economic performance, and social performance. Oyewale's (2019) study highlights that green recruitment and selection play pivotal roles in achieving environmental performance. Tang, Chen, Jiang, Paill, and Jia (2019) also affirm that recruiting individuals with an eco-friendly culture is crucial for environmental performance. Similarly, Bahareh, Akbar, Abdolrahim, and Saeed (2019) emphasize that green recruitment and selection serve as the foundation for organizations to attain environmental performance. Furthermore, Shaban (2019) theoretically demonstrates that green recruitment and selection are significant determinants of environmental sustainability. Therefore, it is hypothesized that:

H1: Green recruitment and selection have a positive relationship with environmental performance

Green Career Development and Environmental Performance

Green career development involves providing employees with environmental awareness training (Oyewole, 2019). A company practices green career development if it identifies and analyzes the environmental training needs of employees to develop the necessary skills and knowledge and to continuously improve training and development programs on environmentally friendly practices. Green career development has the strongest correlation with organizational excellence (Salih, 2020). As noted by the author, organizations pay attention to the environmental training needs of their employees to make them more concerned about environmental issues. A study by Zhang et al. (2019) underscores the indispensable nature of green career development for environmental performance. Similarly, Afum et al. (2020) confirm a substantial correlation between green career development and environmental performance, emphasizing its role in fostering the acquisition of skills and knowledge related to sustainable practices. Fatoki (2019) echoes this sentiment, emphasizing that green career development empowers individuals to cultivate expertise in environmentally friendly technologies and methodologies, thereby enhancing environmental performance. Another study by Kambule et al. (2019) posits that green career development not only fosters innovation and research in environmental sustainability but also contributes to the improvement of environmental performance. This means that

green career development aligns individuals and organizations with sustainable practices and fosters a positive impact on environmental performance through innovation, reduced environmental impact, and an overall commitment to environmental responsibility. Hence, the following hypothesis is proposed:

H2: Green career development has a significant relationship with environmental performance

Green Performance Appraisal and Environmental Performance

Green performance appraisal is when performance assessments include green performance indicators (Pham et al., 2019). A company practices green performance appraisal when it sets environmentally friendly goals and responsibilities and sanctions violations of environmental management goals. In the study of Salih (2020) performance appraisal has the lowest impact on organizational excellence but the correlation was positive and significant. Ardiza et al (2021) also examined the effect of green performance appraisal on employee performance and concluded that improvements in the timeliness of green performance appraisal are a priority to improve employee performance. Ture and Ganesh (2014) found that green performance appraisal serves as a platform for fostering collective efforts among employees toward sustainability. Renwick et al. (2013) support this idea by asserting that green performance appraisal directly correlates with environmental performance. This is because it encourages employees to be more mindful of their environmental impact when their performance is assessed in the context of sustainability. Additionally, Al-Mamun (2019) demonstrates that green performance appraisal significantly predicts environmental performance. Stojanoska (2016) further emphasizes that green performance appraisal acts as an incentive, influencing employees to adopt environmentally conscious behaviors aligned with sustainability. This means that green performance appraisals serve as a strategic tool to promote and strengthen environmentally sustainable practices among employees. By linking individual performance to environmental goals, organizations can foster a culture of sustainability, drive positive behavioral change, and ultimately contribute to improved environmental performance. Thus, the study hypothesized that:

H3: Green performance appraisal has a significant relationship with environmental performance

Green Reward System and Environmental Performance

The green reward system is when a company offers bonuses to employees who carry out environmental tasks, recognizes employees who are classified as environmental champions, and prefers to tailor its compensation package to reflect its environmental goals (Al-Mamun, 2019). According to Salih (2020), the sustainability of organizations' environmental performance is highly dependent on the green reward management system. A study carried out by Masri (2016) illustrates the connection between a green reward system and environmental performance, emphasizing its role in heightening employee awareness of environmental issues. Mandago (2019) supports this idea, highlighting the strong relationship between a green reward system and environmental performance. This connection is attributed to the system's ability to empower employees, fostering a heightened consciousness of their ecological impact both at work and in their personal lives. Saeed et al. (2019) affirm that the implementation of a green reward system actively contributes to cultivating a positive organizational culture centered around sustainability. Similarly, Ture and Ganesh (2014) present evidence that a green reward system serves as a significant determinant of environmental performance. This underscores the notion that such a system not only acknowledges and reinforces positive environmental practices but also plays a pivotal role in fostering a broader cultural and operational shift toward sustainability within an organization. Hence, it is hypothesized that:

H4: Green reward system has a significant relationship with environmental performance

Green Participation and Environmental Performance

Green participation involves empowering employees to make decisions about environmental issues, propose improvements related to environmental sustainability, and recognize employee contributions as important (Shaban, 2019). In the study by Wiradirja et al. (2020), the direct impact of green employee involvement practices on environmental performance was supported. A study conducted by Ahum et al. (2020) underscores that green participation serves as an empowering force, enabling employees to

collectively contribute to positive environmental performance. By fostering the engagement of a substantial number of employees in sustainable practices, it leads to a noteworthy reduction in environmental impact and resource consumption. Similarly, Danso et al. (2019) establish that green participation acts as a roadmap for achieving environmental performance. In line with this perspective, Pham et al. (2020) provide evidence that green participation fosters the efficient utilization of resources, thereby reducing energy consumption, minimizing waste, and conserving water. This contributes significantly to overall resource conservation and sustainability. Qureshi et al. (2019) affirm a direct link between green participation and environmental performance. Likewise, Cahya (2021) asserts that green participation serves as a robust predictor of environmental performance. Furthermore, Alam et al. (2021) reaffirm that green participation operates as a platform that engages employees in green initiatives. This engagement, in turn, contributes to their satisfaction and well-being, aligning with the goals of positive environmental performance. Therefore, it is proposed that

H5: Green participation has a significant relationship with environmental performance

Organizational culture as a mediator

Organizational culture (OC) is a vital component that influences the work environment and assists individuals in realizing how organizations function and provide norms for performance in the organization (Herman et al., 2021; Yong et al., 2020). OC is a system of shared values, assumptions, norms, and traditions that assist individuals in realizing the way organizations function toward achieving environmental sustainability (Shafaei et al., 2020). Previous empirical studies have posited that OC is a platform through which environmental sustainability can be achieved by influencing the thoughts, feelings, and interactions of individuals within a green environment (Afum et al., 2020; Fatok, 2019). In the view of Afum et al. (2020), organizational environmental culture refers to all interactions of employees within an organization and the associated meaning that employees attach to those behaviors towards a green environment. According to Yong et al. (2020), organizations with a pro-environmental culture are more likely to integrate sustainability into their overall strategy, leading to improved environmental performance.

Based on theoretical and empirical evidence, the following hypothesis is formulated:

H6: Organizational culture has a significant relationship with environmental performance

Mediating effect of organizational culture on green recruitment and selection, and environmental performance

Existing research establishes the link between OC, GRS and EP, for instance, Felipe et al. (2017) noted that OC serves as a foundation for management to comprehend the collective values, beliefs, and norms that influence the environmentally conscious behaviors of prospective candidates. Empirically, Adebayo, Worlu, et al. (2020) establish a positive relationship between OC, GRS and EP. In another study, Magsi et al. (2018) confirm a significant relationship between OC, GRS, and EP. In the same vein, Al-Mamun (2019) reveals that OC has a positive link to GRS and EP. Likewise, previous studies have empirically demonstrated that OC is a strong mediator between GRS and EP (Fatok, 2019; Shafaei et al., 2020). In a similar vein, Bahareh, Akbar, Abdolrahim, and Saeed (2019) emphasize that OC serves as the foundational element enabling organizations to identify environmentally friendly potential candidates, thereby positively impacting environmental performance. Thus, the following hypothesis is formulated:

H7: Organizational culture mediates the relationship between green recruitment and selection, and environmental performance

Mediating effect of organizational culture on green career development, and environmental performance

Theoretical research has affirmed a significant association between OC, GCD, and EP. For instance, the moral foundations theory argues that the green behavior of employees is associated with individual characteristics such as beliefs, norms and values, and socio-demographics (Ullah, 2017). According to

Haidt and Joseph (2004), moral foundations theory demonstrates that harm/care and purity/sanctity are associated with a green environment. Therefore, moral passion for the green environment by employees is associated with sustainability and EP. Martins et al. (2021) state that green career development indirectly impacts environmental performance through the mediation of organizational culture (OC). Oyewale (2019) emphasizes the crucial roles played by green career development in attaining environmental performance, particularly within the framework of OC. Tang, Chen, Jiang, Paill, and Jia (2019) additionally confirm the importance of green career development in individuals with an eco-friendly culture as a critical factor for improving environmental performance. Therefore, the following hypothesis is proposed:

H8: Organizational culture mediates the relationship between green career development and environmental performance

Mediating effect of organizational culture on green performance appraisal, and environmental performance

Organizational culture functions as a mediator in the correlation between green performance appraisal and environmental performance outcomes, as noted by Pham et al. (2019). A positive and environmentally supportive culture strengthens the nexus between individual green appraisals, organizational values, and overall sustainability achievements, as highlighted by Salih (2020). Herman et al. (2021) validate that green performance appraisal acts as a platform for fostering collective efforts among employees toward sustainability through organizational culture (OC). Similarly, Yong et al. (2020) confirm that green performance appraisal indirectly correlates with environmental performance through OC. Afum et al. (2020) further emphasize that OC drives green performance appraisal of employees to enhance environmental sustainability. Fatok (2019) also supports previous studies by affirming that OC serves as a mediator between green performance appraisal and environmental performance.

These empirical findings imply that shared values of assumptions, norms, and traditions toward the green environment have a significant relationship with GPA and EP. Thus, the following hypothesis is proposed:

H9: Organizational culture mediates the relationship between green performance appraisal and environmental performance

Mediating effect of organizational culture on green reward system, and environmental performance

The interplay between Organizational Culture (OC) and the relationship connecting a Green Reward System and Environmental Performance is characterized by how the existing values, beliefs, and norms within an organization influence the impact of green rewards on overall environmental outcomes (Herman et al., 2021). As asserted by Su, Ren, and Li (2017), OC assumes a pivotal role in harmonizing the values ingrained in a green reward system with those inherent in the organizational culture. A positive culture that places a premium on environmental sustainability amplifies the efficacy of green rewards. Affirming this perspective, Salih (2020) emphasizes that the integration of a green reward system with the organizational culture fortifies environmentally responsible behaviors, thereby contributing to an enhancement in environmental performance. In a parallel vein, Mandago (2019) underscores that a favorable organizational culture cultivates an environment where employees are driven by green rewards to engage in environmentally friendly behavior, thereby fostering improved environmental performance. Hence, the following hypothesis is proposed:

H10: Organizational culture mediates the relationship between the green reward system and environmental performance.

The mediating impact of organizational culture on green participation and environmental performance

Existing research establishes the indirect impact of green participation on environmental performance through Organizational Culture (OC). For example, Chen et al. (2018) demonstrate that organizational culture influences the connection between employees' involvement in environmentally sustainable practices (Green Participation) and the overall environmental performance of the organization. Afum

et al. (2020) assert that a positive and environmentally conscious culture nurtures a sense of responsibility and dedication to sustainable actions among employees. Similarly, Robertson and Carleton (2018) contend that a culture promoting and rewarding environmentally friendly actions cultivates an environment where employees are more inclined to participate in green initiatives. Huang and Kung (2018) also discover that a positive organizational culture supporting environmental sustainability heightens employee engagement in green practices, thereby contributing to improved environmental performance outcomes. This implies that organizational culture functions as a mediating element by aligning employees' green participation with the broader goals and values of the organization, particularly when these goals align with environmental sustainability, thus enhancing the overall impact on environmental performance. Therefore, the following hypothesis is proposed:

H11: Organizational culture mediates the relationship between participation and environmental performance

Methodology

Respondents

The research population consists of all the senior managers and employees working in food and beverage companies in Southwest Nigeria. The choice of these companies was based on their location in Southwest Nigeria and the belief that they share common GHRM practices and OC policies that promote awareness of environmental sustainability. The population of the study comprised 1,689 managers and employees and the sample size of 323 respondents was determined by the formula suggested by Taro Yamane, as stated below:

$$N / (1 + N\alpha^2) = 1689 / [1 + 1689 \times (.005)^2]$$

$$1689 / (1 + 4.225) = 323$$

The purposive sampling technique which is a non-probability sampling technique was used to select the respondents. This technique was used because the target respondents are senior managers and employees responsible for environmental issues in the selected companies. The survey was distributed to 323 respondents, and it was personally conducted to conveniently select the respondents with the help of two research assistants to ensure prompt attention and responses from the respondents from 20th March 2022 to 25th May 2022. The self-administered questionnaire method allows researchers to ask respondents follow-up questions and collect more information. Respondents were selected based on their direct responsibility for HRM practices, as they are anticipated to possess a keen understanding of the subject matter. The researchers, assisted by two research assistants, administered the questionnaires to participants who volunteered for the study from February 14, 2022, to April 25, 2022. All 323 distributed questionnaires were successfully retrieved, resulting in a 100% response rate. This high response rate may be attributed to the pre-discussion with managers, emphasizing the significance of the study and gaining their acceptance before distributing the questionnaires. Additionally, the involvement of research assistants in clarifying any unclear aspects contributed to the overall response rate.

Description of the research instrument

The structured questionnaires were designed for respondents of selected food and beverages companies operating in Southwest Nigeria; which comprised the green recruitment and selection scale (GRSS), green career development scale (GCS), green performance appraisal scale (GPAS), green reward system scale (GRS), green participation scale (GPS), organizational culture scale (OGCS), and environmental performance scale (EPS). A 5-point Likert scale was used for all questionnaire measurements ranging from 1 (strongly disagree) to 5 (strongly agree) as follows:

Green Recruitment and Selection Scale: This construct was created and validated by Mandago (2019) and include a total of 5 items. Sample items include: "In placing a job advert, my organization expresses certain environmental value," "My organization selects applicants that have sufficient knowledge of greening to fill the vacant position," and "When interviewing applicants, my organization asks about an employee-related environmental issue." The author reported a KMO value of 0.781, a principal component value eigenvalue of 2.679, and a variance of 92.56%. This indicates that the exploratory factor analysis confirmed the consistency of the constructs.

Green Career Development Scale: This construct was developed and validated by Oyewole (2019) and has a total of 5 items, including: “My company provides employees with environmental awareness training to gain a competitive advantage in the industry,” “My company identifies and analyzes the environmental training needs of employees to develop the necessary skills and knowledge,” and “My company continuously improves training and development programs on environmentally friendly practices.” The author reported a KMO value of 0.847, a principal component value eigenvalue of 3.608, and a variance of 72.34%.

Green Performance Appraisal Scale: This construct was created and validated by Pham et al. (2019) and has a total of 5 items. Sample items include: “At my company, performance assessments include green performance indicators,” “My company sets environmentally-friendly goals and responsibilities” and “My company sanctions violations of environmental management goals.” The authors reported a KMO value of 0.644, a principal component value eigenvalue of 1.878, and a variance of 61.89%.

Green Reward System Scale: This construct was created and validated by Al-Mamun (2019) and has a total of 5 items. These include: “My company offering bonuses to employees who carry out environmental issues,” “My company recognizes employees who are classified as environmental champions,” and “My company prefers to tailor its compensation package to reflect its environmental goals.” The author reported a KMO value of 0.798, a principal component value eigenvalue of 3.072, and a variance of 73.14%.

Green Participation Scale: This construct was created and validated by Shaban (2019) and has a total of 4 items which include: “In my company, employees can make many decisions about environmental issues,” “Employees are encouraged to propose improvements related to environmental sustainability,” and “Employee contributions are considered important and will be made in good faith.” The author reported a KMO value of 0.774, a principal component value eigenvalue of 1.956, and a variance of 81.25%.

Organizational Culture Scale: This construct was created and validated by Shafaei et al. (2020) and has a total of 5 items. The items include: “My organization has strict environmental regulations to comply with,” “We follow our environmental procedures within the organization” and “Our organization acts cautiously on all environmental issues.” The authors reported a KMO value of 0.81, a principal component value eigenvalue of 3.310, and a variance of 75.09%.

Environmental Performance Scale: This construct was created and validated by Adebayo et al. (2020) and has a total of 5 items which include: “Environmental performance has led to the establishment of the Green Team,” “Ecological sustainability allows my company to act in an environmentally friendly way” and “My company has an environmental budget.” The authors reported a KMO value of 0.79, a principal component value eigenvalue of 2.976, and a variance of 76.93%.

Psychometric characteristics of the scales

The study used both exploratory (Table 1a, Table 1, Table 2 and Table 3) and confirmatory factor (Table 3a, Table 3b and Table 3c) analyses evaluate the dimensionality of scales (See Tables). The exploratory factor analysis used the oblique perspective with varimax rotations for all measures. The results of analyses support the unidimensionality of all scales. Subsequently, the study tested the measurement and structural relationships of the research models concurrently using the major goodness of fit indices like the RMSE, GFI and Equation level goodness of fit. The results of the tests validate the seven latent variables of environmental performance, Green recruitment and selection, Green career development, Green performance appraisal, Green reward system, Green participation, and Organizational culture. Overall, the goodness of fit test results suggest that the estimated model is reasonably consistent with the covariance matrix. Further evidence suggests a good construct validity from the convergent and divergent validities.

Results and Discussion

Demographic Analysis

The demographic data shows that more respondents were in the age group between 31-40, followed by 41-50, 20-30, and 50+ in the order of 120 (37.2%), 104 (32.2%), 70 (21.6%), and 29 (9%), respectively. From this, we can infer that most of the employees of the selected food and

beverage companies fall within the category of productive age. This finding implies that the food and beverages industry can still play a pivotal role in Nigeria's environmental sustainability. The result also reveals that about 145 (44.9%) respondents had over nine years of experience, while 98 (30.3%) respondents indicated they had been in their organizations for between six and eight years. Of the respondents, 54 (16.7%) had three to five years of experience and only 26 (8.1%) had been in their organizations for less than three years. Therefore, a larger percentage of the respondents had more than nine years of experience and thus should be knowledgeable about the integration of GHRM into EP. The analysis of the results indicates that 176 (54.3%) of the respondents had B.Sc/HND certificates; 92 (28.3%) had ND/NCE certificates, while 38 (11.7%) had a master's degree. In addition, only 17 (5.2%) had other certificates but had received on-the-job-training. Therefore, most of the respondents had some form of formal education with a human resource background and thus should have been able to answer the questions asked competently.

Validity of the instrument

The study used convergent and discriminant validity techniques to assess the validity of the study's questionnaire. The author administered the questionnaire to several respondents in a pilot test, coded the responses and employed the coded results to compute the average variance extracted (AVE) from exploratory factor analysis. The AVE served to determine both the convergent and discriminant validities. Specifically, after the exploratory factor analysis, the following formula was used to compute the AVE:

$$\text{AVE} = \frac{\sum \lambda_i^2}{n}$$

where:

λ_i = factor loadings

. n = number of loadings

Cut-off for convergent validity is 0.5 (Chen et al., 2023). All the computed AVEs for GRS, GCD, GWR, GPA, GP, OC and EP are more than 0.5, thus establishing convergent validity (See Table 1). After determining the convergent validity, the author also computed the discriminant validity, which requires the computation of the correlation coefficients. The study calculated the correlations and compared them with the square roots of the AVEs. The two validities help to validate the measuring instrument because the convergent validity helps to indicate the extent to which the measure sufficiently corresponds to measures of related constructs. The computed discriminant validity provides an indication of the degree to which the items are unrelated or negatively related to measures of distinct constructs. The results show that all the AVEs in the main diagonal are more than the corresponding correlation coefficients below the diagonals. To this end, discriminant validity is established (See Table 4).

Reliability

The study used the composite reliability technique to assess the reliability of the instrument. The computation of the composite reliability also employed the results of the AVE. The calculation of the composite reliability is as follows:

$$\text{Composite Reliability: } \frac{(\sum \lambda_i)^2}{(\sum \lambda_i)^2 + \sum e_i}$$

where:

. λ_i = factor Loadings (Standardised factor loadings)

. $e_i = 1 - \lambda_i^2$

All the computed values of the composite reliabilities of GRS, GCD, GWR, GPA, GP, OC and EP are more than 0.5, thus establishing composite reliability for all the constructs. This implies that the research instrument is both reliable and internally consistent.

Table 1. Convergent Validity $AVE = \left(\frac{\sum \lambda_i}{n} \right)^2$

1	GRS	$\left(\frac{4.359}{5} \right)^2$	0.8718 ²	0.760
2	GCD	$\left(\frac{4.062}{5} \right)^2$	0.8124 ²	0.660
3	GRW	$\left(\frac{4.02}{5} \right)^2$	0.804 ²	0.646
4	GPA	$\left(\frac{3.825}{5} \right)^2$	0.765 ²	0.585
5	GP	$\left(\frac{3.959}{5} \right)^2$	0.7918 ²	0.627
6	OC	$\left(\frac{4.017}{5} \right)^2$	0.8034 ²	0.645
7	EP	$\left(\frac{3.968}{5} \right)^2$	0.7936 ²	0.630

Composite Reliability:

where:

. λ_i = factor Loadings (Standardised factor loadings). $e_i = 1 - \lambda_i^2$ **Table 2.** Residuals

	e_1	e_2	e_3	e_4	e_5	$\sum e_i$
GRS	0.2274	0.3111	0.1332	0.2758	0.2466	1.1941
GCD	0.2379	0.4931	0.2775	0.3455	0.3309	1.6849
GRW	0.5128	0.2587	0.3853	0.2291	0.4816	1.381
GPA	0.4148	0.3078	0.3900	0.4715	0.4816	2.0657
GP	0.3439	0.3568	0.3648	0.4209	0.3775	1.8639
OC	0.3743	0.2258	0.3963	0.3775	0.3455	1.7194
EP	0.3407	0.3775	0.3568	0.3390	0.4345	1.8400

Table 3. Composite Reliability

1.	.GRS	$\frac{4.359^2}{4.359^2 + 1.1941} = \frac{19}{19 + 1.1941}$	= 0.940
2.	.GCD	$\frac{4.062^2}{4.062^2 + 1.6849} = \frac{16.4998}{16.4998 + 1.6849}$	= 0.907
3.	.GWR	$\frac{4.02^2}{16.1604^2 + 1.381} = \frac{16.1604}{16.1604 + 1.381}$	= 0.921
4.	.GPA	$\frac{3.825^2}{3.825^2 + 2.066} = \frac{14.631}{14.631 + 2.066}$	= 876
5.	.GP	$\frac{3.959^2}{3.958^2 + 1.864} = \frac{15.674}{15.674 + 1.864}$	= 894
6.	OC	$\frac{4.017^2}{4.017^2 + 1.7194} = \frac{16.1363}{16.1363 + 1.7194}$	= 904
7.	EP	$\frac{3.968^2}{3.968^2 + 1.84} = \frac{15.745}{15.745 + 1.84}$	= 895

Table 4. Discriminant Validity

	1	2	3	4	5	6	7
1.GRS	0.872						
2.GCD	0.654	0.812					
3.GPA	0.132	0.163	0.804				
4.GWR	0.723	-0.164	0.791	0.765			
5.GP	0.329	-0.129	0.657	0.699	0.792		
6.OC	0.071	0.088	0.775	0.752	0.699	0.803	
7.EP	0.236	0.154	0.696	0.748	0.767	0.793	0.794

Path analysis

The data collected were analyzed using correlation and structural equation modeling with the aid of STATA version 15.

Table 5. Results on the relationship between variables

Model	Mean	SD	R-value	p-value	Remark
GRS	4.538462	.6044091	0.6667*	P<0.05	S
GCD	4.419231	.612936	0.5831*	P<0.05	S
GPA	3.553846	.9985436	0.0369	P>0.05	NS
GR	4.438462	.6024896	0.6062*	P<0.05	S
GP	4.319231	.7152607	0.1784	P>0.05	NS
OC	4.557692	.6028716	0.6497*	P<0.05	S

S= Significant; NS= Not significant; *= significant at 5% level

Table 5 shows the link between the dependent variable (EP) and independent variables (green recruitment and selection, green career development, green performance appraisal, green reward system, green participation, and organizational culture). The results show that green recruitment and selection ($r = 0.6667^*$), green career development ($r = 0.5831^*$), and green reward system ($r = 0.6062^*$) are positively and significantly related to EP. The study is aligned with the work of Tang, Chen, Jiang, Paill, and Jia (2019) that reinforces the managerial significance of recruiting individuals with an eco-friendly culture for enhancing environmental performance. Additionally, the correlation between green career development and environmental performance, as supported by Afum et al. (2020), emphasizes the managerial role in fostering skills and knowledge related to sustainable practices. Moreover, the confirmation by Saeed et al. (2019) that a green reward system contributes to cultivating a positive organizational culture centered around sustainability further highlights the managerial imperative of implementing such systems. This is consistent with the findings of Ture and Ganesh (2014), who establish the green reward system as a significant determinant of environmental performance. Therefore, the results underscore the managerial relevance of implementing green recruitment and selection, green career development, and green reward systems, aligning with existing literature that emphasizes their positive impact on environmental performance. Furthermore, organizational culture (OC) exhibited a positive and significant correlation with environmental performance (EP) ($r = 0.6062^*$). This discovery aligns with the assertion made by Yong et al. (2020) that organizations fostering a pro-environmental culture are inclined to integrate sustainability into their overall strategy, consequently enhancing environmental performance.

Conversely, green performance appraisal ($r = 0.0369$) and green participation ($r = 0.1784$) display a positive but statistically insignificant association with environmental performance (EP). This result contradicts prior studies, such as those by Pham et al. (2019), Salih (2020), and Ardiza et al. (2021), which found a positive and significant impact of green performance appraisal on employee performance.

This discovery implies that Nigeria's food and beverage companies shared common values, assumptions, norms, and traditions that assist their employees to realize the way organizations function towards achieving environmental sustainability and performance.

Table 6. Results of the Structural Equation Model

Path	Coefficient	Std. Err.	T-value	P-value	Hypotheses
Direct Model					
GRS → EP	0.536752	.0808584	6.64	0.000*	H ₁ Confirmed
GCD → EP	0.1139754	.0361069	3.16	0.002*	H ₂ Confirmed
GPA → EP	0.0217342	.0413781	1.23	0.218	H ₃ Not confirmed
GR → EP	0.0425089	.0250782	1.03	0.304	H ₄ Not Confirmed
GP → EP	0.0328583	.0250782	1.31	0.190	H ₅ Not confirmed
OC → EP	0.2415828	.0862275	2.80	0.005*	H ₆ Confirmed
Indirect Model					
GRS → OC → EP	.2000091	.0716929	2.79	0.005*	H ₇ Partially Confirmed
GCD → OC → EP	-.0050588	.0065208	-0.78	0.438	H ₈ Not confirmed
GPA → OC → EP	-.0001823	.0030678	-0.06	0.953	H ₉ Not confirmed
GR → OC → EP	.0443798	.0171765	2.58	0.010*	H ₁₀ Confirmed
GP → OC → EP	.0051296	.0047157	1.09	0.277	H ₁₁ Not confirmed

* = Significance at the level of 5%.

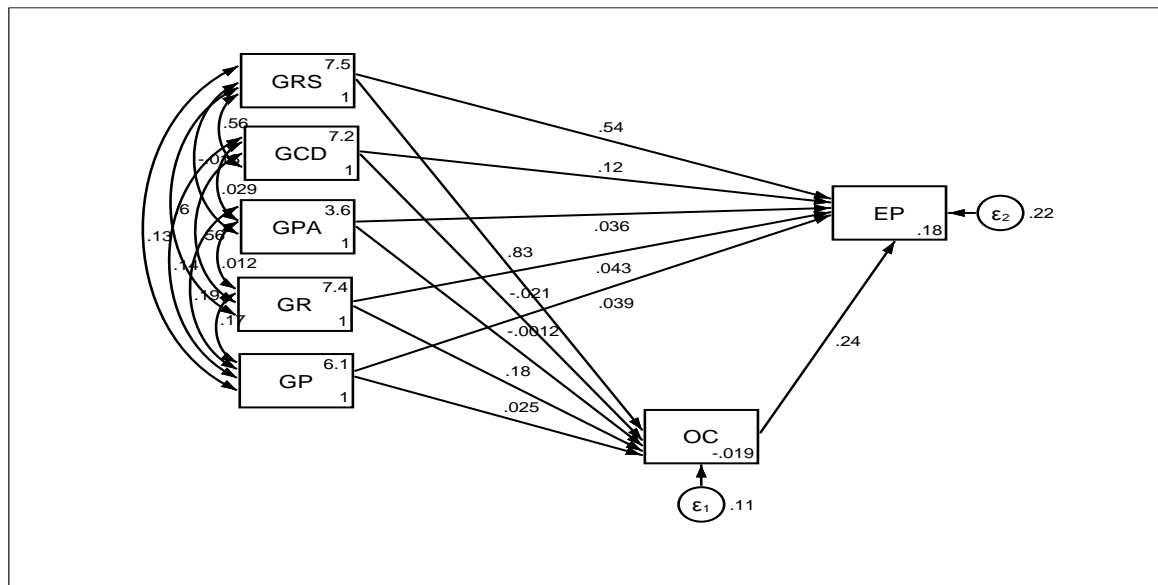

Fig. 1. Structural Equation Model

GRS-Green Recruitment and Selection, GCD-Green Career Development, GPA-Green Performance Appraisal, GR-Green Reward System, GP-Green Participation, OC-Organizational Culture and EP-Environmental Performance
Source: Data computation, 2022

Table 6 and Figure 1 show the relationship between EP, green recruitment and selection, green career development, green performance appraisal, green reward system, green participation, and organizational culture. The calculated z and asymptotically significant probabilities associated with the test are 6.64 (0.000*), 3.16 (0.002*), 1.23 (0.218), 1.03 (0.304), 1.31 (0.190), and 2.80 (0.005*) for green recruitment and selection, green career development, green performance appraisal, green reward system, green participation, and OC, respectively. Therefore, EP is positively linked to green recruitment and selection, green career development, green performance appraisal, green reward system, green participation, and OC. However, while the relationships between EP, green recruitment and selection, green career development, and OC were significant, the relationship between EP, green performance appraisal, green reward system, green participation, and OC were not significant but positive. This indicates that green recruitment and selection, green career development, and OC independently and significantly influence EP. Therefore, H1, H2, and H6 are accepted, while H3, H4, and H5 are not confirmed.

Table 6 and Figure 1 further show that GRS has a significant association with EP when OC is not introduced. When OC is introduced, the p-value is 0.005, indicating that OC and GRS are predictors of EP. This means that OC is a partial mediator between GRS and EP. Evidence also demonstrates that GR is not a predictor of EP with a p-value of 0.304; however, when OC is introduced, the p-value drops to 0.0100, suggesting that OC is a mediator between GR and EP. The results also show that GCD is a predictor of EP with a p-value of 0.002, but the p-value changed to 0.438 when OC was introduced. This indicates that OC does not mediate between GCD and EP. Furthermore, p-values of 0.218 and 0.190 indicate that GPA and GP are not predictors of EP. When OC was introduced, the p-values increased to 0.953 and 0.277, respectively. This means that OC does not meet the criteria as an intermediate variable between GPA, GP, and EP (See Figure 1). Hence, H7 is partially supported and H10 is confirmed, while H8, H9, and H11 are not supported.

Discussion

This study is consistent with previous studies confirming that GHRM practices are predictors of EP (Mandago; 2019; Mwita, 2019; Shaban, 2019; Zhang et al., 2019). The study of Shaban (2019) establishes that GHRM and its application practices have a significant effect on sustainability and EP.

Similarly, Al-Mamun (2019) confirms that GHRM is an alternative paradigm for sustainable development and EP. Also, the study of Pham et al. (2019) reaffirms that GHRM practices are the impetus for EP. In agreement with the study of Martins et al (2021) green recruitment and selection were found to be significant. Also, green career development was found significant in line with Salih (2020). Contrary to previous findings that green performance appraisal, green reward system, and green participation significantly influence environmental performance (Al-Mamun, 2019; Shaban, 2019; Salih, 2020; Wiradirja et al., 2020; Ardiza et al., 2021) this study did not confirm their impact on environmental performance.

Moreover, the current finding supports the previous empirical studies' assertion that OC is a platform in which environmental sustainability and performance can be achieved by influencing the thoughts, feelings, and interactions of individuals through the green environment (Afum et al., 2020; Fatok, 2019). This study is consistent with the study by Felipe et al. (2017) which indicate that OC is a prediction of the organization's environmental culture. In another study, Adebayo et al. (2020) established a positive relationship between OC and EP. Magsi et al (2018) also confirm that there is an important link between OC and EP. Similarly, Mujeeb and Ahmad (2011) show that OC has a positive and significant impact on EP. This is consistent with the guidelines proposed by Baron and Kenny (1986), and Hair et al. (2010) that partial mediation occurs when both the independent variable and the mediator are predictors, while full mediation occurs when the independent variable is not the predictor, and the mediator is the predictor. Mediation does not occur if the independent variable is a predictor and the mediator is not.

This finding implies that Nigeria's green movement is improving and that food and beverage companies are committed to reducing environmental threats, stimulating the economy, promoting industrial sustainability, and environmental protection policies, thereby actualizing the 2030 Agenda for Sustainable Development through pro-environment policies and corporate programs.

Conclusion

Environmental issues have become a major concern worldwide because the manufacturing activities of companies hurt the environment. As such, this study examined the direct relationship between green HRM practices (green recruitment and selection, green career development, green performance appraisal, green reward system, green participation) and EP. To contribute to the body of knowledge in environmental sustainability, this study investigated the mediating effect of OC between green HRM practices and EP. The research shows that EP is positively related to green HRM practices (green recruitment and selection, green career development, green performance appraisal, green reward system, and green participation). However, the direct effect indicates that only green recruitment and selection and green career development were found to be significant. The indirect effect of OC as a mediating factor shows that the green reward system and green recruitment and selection were significant. The main contribution of this study is to link EP with green HRM practices through OC and elucidate the role of organizational culture in environmental sustainability.

Theoretical Implications

The theoretical implication of this study lies in its significant contribution to the theoretical foundation of environmental management, particularly within the realm of green human resource management (GHRM). The research enhances existing literature by incorporating and applying three distinct theories—Resource-Based View Theory, Ability, Motivation, and Opportunity Theory (AMO), and Moral Foundations Theory (MFT)—to understand and interpret the relationship between GHRM practices, organizational culture (OC), and environmental performance (EP). The chosen theories provide a comprehensive framework for practical application in the context of the Nigerian food and beverage industry, which is characterized by high dynamism and competitiveness. The industry's unique challenges, including environmental uncertainty and risk, necessitate the adoption of various strategies and policies.

The study affirms the validity of the theories' propositions, specifically indicating a positive interaction between GHRM practices, OC, and EP. Consequently, the theoretical implications highlight the importance of promoting specific GHRM practices, such as green recruitment and selection, green training and development, green performance evaluation, and green reward programs.

Furthermore, the study suggests that fostering a culture of environmentally friendly practices within the workforce can lead to positive outcomes. Employees, when equipped with the right green knowledge and skills, are likely to contribute to improved environmental performance by reducing waste, minimizing energy consumption, enhancing productivity, improving product quality, and increasing overall income. This aligns with the foundational principles of the identified theories and reinforces the practical relevance of integrating GHRM practices to address environmental challenges in a dynamic and competitive industry.

Practical Implications

Environmental sustainability has recently attracted the attention of industry practitioners and policymakers (UNEP, 2020). This study advances the literature on GHRM such that the findings could be practical for managers, practitioners, policymakers, and academicians. Moreover, there is a notable research gap on the mediating role of organizational culture between GHRM practices and environmental performance in the Nigerian manufacturing industry. Thus, this study provides significant practical contributions to the manufacturing industry in Nigeria, and the food and beverage industry in particular. The food and beverage industry is critical to the Nigerian economy in terms of financial contributions and employment. This is because the industry is the largest manufacturing sector in Nigeria and Africa (Vlaanderen, 2020). The study established a positive relationship between green HRM practices and EP. Based on the findings of the study, there is a need to move towards GHRM practices and develop a culture that fosters its implementation. It is expected that the food and beverage industry in Nigeria will undergo a moral shift to GHRM practices through green recruitment and selection, green career development, and a green reward system. The study also proved the role of organizational culture in environmental performance. The Nigerian food and beverage industry is highly competitive, with several players seeking innovative competencies to boost performance. The results of this study can be used in the industry to propose suggestions for human resource managers to devise environment-friendly strategies that will enhance organizational environmental performance. Therefore, food and beverage companies in Nigeria and other countries need to establish a sound organizational culture that fosters green human resource management practices. The findings of this study also provide important implications for organizational policymakers. It will assist them in reducing environmental threats, promoting industrial sustainability, and the actualization of the 2030 Agenda for Sustainable Development. Therefore, incorporating Green Human Resource Management (GHRM) practices into organizational strategies is recommended for managers. The consistent findings from various studies emphasize the positive impact of GHRM practices on Environmental Performance (EP). This entails integrating green recruitment, selection, and career development practices. The study highlights the significance of Organizational Culture (OC) in attaining environmental sustainability and performance. Managers should give priority to cultivating a green organizational culture that shapes employees' thoughts, feelings, and interactions, thereby contributing to favourable environmental outcomes. Acknowledging the mediating role of Organizational Culture in the relationship between GHRM practices and EP is crucial for managers. This suggests that nurturing a green organizational culture can amplify the effectiveness of GHRM practices in promoting environmental sustainability and performance.

Limitations and recommendations for further studies

This study has limitations that may stimulate further studies. This study focused on the food and beverage sector: hence future studies may include oil and gas, cement industry, mining, and more. This broader scope will allow for depth, thus contributing to the generality of the results. The study examined three theories in determining the effect of GHRM and OC on EP. Therefore, further examination of the excluded theories -Theory of Planned Behavior (TPB), Linking Instrumental Theory (LIT), and Value Belief Norms Theory (VBNT)- will be necessary to expand the frontiers of knowledge.

References

- Adebayo, O. P., Worlu, R. E., Moses, C. L. & Ogunnaike, O. O. (2020). An integrated organizational culture for sustainable environmental performance in the Nigerian context. *Sustainability*, 12, 8323; 1-15.
- Aftab, J., Abid, N., Cucari, N., & Savastano, M. (2023). Green human resource management and environmental performance: The role of green innovation and environmental strategy in a developing country. *Business Strategy and the Environment*, 32(4), 1782–1798. <https://doi.org/10.1002/bse.3219>
- Afum, E., Agyabeng-Mensah, Y. & Owusu, J. A. (2020). Translating environmental management practices into improved environmental performance via green organizational culture: Insight from Ghanaian manufacturing SMEs. *Journal of Supply Chain Management System*, 9, 31–49.
- Al-Mamun, M. A. (2019). An analysis of employee awareness on green human resource management practices: Evidence from Bangladesh. *Human Resource Management Research*, 9(1): 14-21.
- Appelbaum, E., Bailey T., Berg P., & Kalleberg A. (2000). *Manufacturing advantage: Why high performance work systems pay off*. Itacha, Cornell University Press.
- Ardiza, F., Nawangsari, L. C., & Sutawidjaya, A. H. (2021). The influence of green performance appraisal and green compensation to improve employee performance through OCBE. *International Review of Management and Marketing*, 11(4), 13–22.
- Barney, J. B. (1986). Organizational culture: Can it be a source of sustained competitive advantage? *The Academy of Management Review*, 11(3), 656-665.
- Baron, R.M., & Kenny, D.A. (1986). The moderator-mediator variable distinction in social psychological research: Conceptual, strategic, and statistical considerations. *Journal of Personality and Social Psychology*, 51,1173–1182.
- Brown, D., & McGranahan, G. (2016). The urban informal economy, local inclusion and achieving a global green transformation. *Habitat International*, 53, 97–105. <https://doi.org/10.1016/j.habitatint.2015.11.002>
- Chen, Y., Lin, S., & Chang, C. (2018). How environmental regulations affect the operation of firms: Evidence from China's polluting firms. *Technological Forecasting and Social Change*, 131, 236-243.
- Chen, J. and Waters, G. (2023). Firm efficiency, advertising and profitability: Theory and evidence *The Quarterly Review of Economics and Finance*, 63, 240-248
- Dierickx, I., & Cool, K. (1989). Asset stock accumulation and sustainability of competitive advantage. *Management Science*, 35(12), 1504-1511.
- Fatoki, O. (2019). Green marketing orientation and environmental and social performance of hospitality firms in South Africa. *Foundations of Management*. 11, 277–290
- Fawehinmi, O., Yusliza, M. Y., Mohamad, Z., Noor Faedah, J., & Muhammad, Z. (2020). Assessing the green behavior of academics: The role of green human resource management and environmental knowledge. *International Journal of Manpower*, 41(7), 879–900.
- Felipe, C.M., Roldán, J.L., & Leal-Rodríguez, A. L. (2017). Impact of organizational culture values on organizational agility. *Sustainability*, 9, 2354
- Graham, J., Nosek, B. A., Haidt, J., Iyer, R., Koleva, S., & Ditto, P. H. (2011). Mapping the moral domain. *Journal of Personality and Social Psychology*, 101(2), 366–385.
- Haidt, J., & Joseph, C. (2004). Intuitive ethics: How innately prepared intuitions generate culturally variable virtues. *Daedalus*, 133(4), 55–66.
- Hair, J. F., Black, W. C., Babin, B. J., Anderson, R. E., & Tatham, R. L. (2010), *Multivariate Data Analysis* (7th ed.). Prentice-Hall.
- Herman, L. E., Udayana, I. B. N., & Farida, N. (2021). Young generation and environmental friendly awareness: Does it the impact of green advertising? *Business: Theory and Practice*, 22(1), 159–166. <https://doi.org/10.3846/btp.2021.12417>
- Herman, H. M., Renz, L. O., & Horner, M. T. (2021). The influence of green human resource management on environmental performance: A case study of manufacturing firms. *Sustainability*, 13(4), 2057.
- Kambule, N., Yessoufou, K., Nwulu, N., & Mbohwa, C. (2019). Exploring the driving factors of prepaid electricity meter rejection in the largest township of South Africa. *Energy Policy*, 124, 199–205. <https://doi.org/10.1016/j.enpol.2018.09.041>
- Kuo Y. K., Khan T. I., Islam S. U., Abdullah F. Z., Pradana M. & Kaewsang-on R. (2022). Impact of Green HRM practices on environmental performance: The mediating role of green innovation. *Frontiers in Psychology*. 13, 916723. doi: 10.3389/fpsyg.2022.916723
- Ljubljana.Tezel, E., & Giritli, H. (2019). Understanding pro- environmental workplace behavior: A comparative study. *Facilities*, 37(9–10), 669–683. <https://doi.org/10.1108/F-12-2017-0134>

- Mandago, R. J (2019). *Influence of green human resource management practices on environmental sustainability in service based state corporations in Kenya* [Doctoral dissertation, Jomo Kenyatta University of Agriculture and Technology].
- Magsi, H. B., Ong, T. S., Ho, J. A., & Hassan, A. F. S. (2018). Organizational culture and environmental performance. *Sustainability, 10*, 2690.
- Martins, J. M., Aftab, H., Mata, M. N., Majeed, M. U., Aslam, S., Correia, A. B. & Mata, P.N. (2021). Assessing the impact of green hiring on sustainable performance: Mediating role of green performance management and compensation. *International Journal of Environmental Research and Public Health, 18*, 5654. <https://doi.org/10.3390/ijerph18115654>
- Martinelli, S. (2013). *The association between the moral foundations theory, ethical concern and fast food consumption* [Master's Thesis, Arizona State University].
- Masri, H. (2016). *Assessing green human resource management practices in West Bank: An exploratory study* [Master's thesis, An-Najah National University].
- Mujeeb, E., & Ahmad, M. S. (2011). Impact of organizational culture on performance management practices in Pakistan. *International Management Review, 7*(2), 52-57.
- Mwita, K. M. (2019). Conceptual review of green human resource management practices. *East African Journal of Social and Applied Sciences, 1*(2), 13-20.
- Oyewole, O (2019). *Green Human Resource Management Practices (GHRM) and Its Effect on Sustainable Competitive Edge in the Nigerian Manufacturing Industry*. [MBA Thesis, Dublin Business School].
- Pham, N. T., Tučkov, Z., & Phan, Q. P. T. (2019). Greening human resource management and employee commitment toward the environment: An interaction model. *Journal of Business Economics and Management, 20*(3), 446-465. <https://doi.org/10.3846/jbem.2019.9659>.
- Ren, S., Tang, G. & Jackson, S. E. (2018). Green human resource management research in emergence: A review and future directions. *Asia Pacific Journal of Management, 35*(3), 769-803.
- Renwick, D. W. S., Redman, T., & Maguire, S. (2013). Green human Resource management: A review and research agenda. *International Journal of Management Reviews, 15*,: 1–14.
- Robertson, J. L., & Carleton, E. (2018). A sense of purpose: The role of values in workers' experience of meaningful work. *Review of General Psychology, 22*(3), 320-334.
- Saeed, B., Afsar, B., Hafeez, S., Khan, I., Tahir, M., & Afridi, M. A. (2019). Promoting employee's proenvironmental behavior through green human resource management practices. *Corporate Social Responsibility and Environmental Management, 26*(2), 424–438. <https://doi.org/10.1002/csr.1694>
- Safari, A., Salehzadeh, R., Panahi, R., & Abolghasemian, S. (2018). Multiple pathways linking environmental knowledge and awareness to employees' green behavior. *Corporate Governance: The International Journal of Business in Society, 18*(1), 81–103. <https://doi.org/10.1108/CG-08-2016-0168>
- Saifulina, N., & Carballo-Penela, A. (2017). Promoting sustainable development at an organizational level: An analysis of the drivers of workplace environmentally friendly behaviour of employees. *Sustain. Dev, 25*, 299–310.
- Salih, D.Q.M. (2020). The impact of green human resources management practices on organizational excellence: An empirical study. *Management and Economics Research Journal, 6*(3), 1119826. <https://doi.org/10.18639/MERJ.2020.1119826>
- Schmit, M. J., Fegley, S., Esen, E., Schramm, S., & Tomassetti, A. (2012). Human resource management efforts for environmental sustainability: A survey of organizations. *Managing Human Resources for Environmental Sustainability, 61-80*.
- Shaban, S. (2019). Reviewing the concept of green HRM (GHRM) and its application practices (Green Staffing) with suggested research agenda: A review from literature background and testing construction perspective. *International Business Research, 12*(5), 86- 94
- Shafaei, A., Nejati, M. & Yusoff, Y. M. (2020). Green human resource management: A two-study investigation of antecedents and outcomes, *International Journal of Manpower, Advanced online publication*. <https://doi.org/10.1108/IJM-08-2019-0406>
- Stojanoska, A. (2016). *Green human resource management: A case Of Gorenje Group* [Master's Thesis, University of Tajeddini, K., Martin, E., & Altinay, L. (2020). The importance of human-related factors on service innovation and performance. *International Journal of Hospitality Management, 85*, 102431. <https://doi.org/10.1016/j.ijhm.2019.102431>
- Tezel, E., & Giritli, H. (2019). Understanding pro-environmental workplace behavior: A comparative study. *Facilities, 37*(9/10), 669-683.
- Ture, R. S., & Ganesh, M. P. (2014). Understanding pro-environmental behaviours at workplace: Proposal of a model.

- Asia-Pacific Journal of Management Research and Innovation*, 10(2), 137–145.
<https://doi.org/10.1177/2319510X14536219>
- Ullah, M. (2017). Integrating environmental sustainability into human Resource management: A comprehensive review on green human resource management. *Maghreb Review of Economics and Management*, 4(1), 6-22.
- UNEP (2020). Presentation on the Global Tailings Review. Available <http://wedocs.unep.org/handle/20.500.11822/33386?show=full>
- Vanderploeg, J., & Lee, S. J. (2019). Factors influencing pro-environmental behaviors in craft businesses. *Clothing and Textiles Research Journal*, 37(1), 51–65. <https://doi.org/10.1177/0887302X18800394>.
- Vlaanderen (2020). Food and beverage industry in Nigeria, market overview. www.flandersinvestmentandtrade.com
- Wiradirja, I. R., Ras, H., Pranadita, N., Macmud, S., Anwar, H., & Haspada, D. (2020). Environmental performance: Role of green employee involvement practices, green training and green shared vision. *Journal of Security and Sustainability Issue*, 10(2). [http://dx.doi.org/10.9770/jssi.2020.10.2\(28\)](http://dx.doi.org/10.9770/jssi.2020.10.2(28))
- Wright, P. M., Dunford, B. B. & Snell, S. A. (2001). Human resources and the resource based view of the firm. *Journal of management*, 27(6), 701-721.
- Yong, J. Y., Yusliza, M.-Y., Ramayah, T., ChiappettaJabbour, C. J., Sehnem, S., & Mani, V. (2020). Pathways towards sustainability in manufacturing organizations: Empirical evidence on the role of green human resource management. *Business Strategy and the Environment*, 29(1), 212–228.
- Zhang, Y. J., Luo, Y., Zhang, X., & Zhao, J. (2019). How green human resource management can promote green employee behavior in China: A technology acceptance model perspective. *Sustainability*, 11(19), 5408.