

PAPER • OPEN ACCESS

Preliminary results of measurements obtained from a low-cost arduino-based surface weather data acquisition system for radio meteorology

To cite this article: M O Osinowo *et al* 2021 *J. Phys.: Conf. Ser.* **2034** 012005

View the [article online](#) for updates and enhancements.

You may also like

- [Effects of Atmospheric Water Vapor on Infrared Interferometry](#)
M. Mark Colavita, Mark R. Swain, Rachel L. Akeson et al.
- [Out-of-transit Refracted Light in the Atmospheres of Transiting and Non-transiting Exoplanets](#)
Paul A. Dalba
- ["Refractivity-from-clutter" based on local empirical refractivity model](#)
Xiaofeng Zhao and



ECS **240th ECS Meeting**
Digital Meeting, Oct 10-14, 2021
We are going fully digital!
Attendees register for free!
REGISTER NOW

Preliminary results of measurements obtained from a low-cost arduino-based surface weather data acquisition system for radio meteorology

M O Osinowo^{1,a}, A A Willoughby¹, O F Dairo^{1,b}, T Ewetumo² and L B Kolawole¹

¹Department of Physical Sciences, Redeemer's University, Ede, Osun State, Nigeria.

²Department of Physics, Federal University of Technology, Akure, Nigeria.

Corresponding author: osinowom@run.edu.ng, dairof@run.edu.ng

Abstract. Surface weather monitoring is crucial for radio meteorology, agricultural, communication, and industrial processes. However, there is a dearth of weather data in Ede, Osun State, Nigeria (Lat 7.736° N, Lon 4.435° E). The proposed weather monitoring system used the Arduino Mega2560 microcontroller to measure, record and display the atmospheric parameters. Analog sensors for pressure, temperature, relative humidity, and wind speed were interfaced with the microcontroller through an ADC for digital signal conversion and data logging. An LCD connected to the microcontroller displays the measured parameters. The weather data were stored in excel format on a microSD card. The data were compared with that of a nearby weather station. The plots showed a close agreement with the data collected from the nearby station. The system eliminates the need for extra cost baud rate and expensive third-party software for interfacing. Besides, there is no need for an internet connection for configuration. Hence, this data acquisition system (DAS) could be a better choice in cost and maintenance than the off-the-shelf weather stations. The DAS was programmed to derive the surface radio refractivity from the meteorological parameters and the corresponding radio refractivity gradients over Ede.

1. Introduction

In nearly all higher institutions and agencies in Nigeria that engage in weather monitoring or other research purposes, most data acquisition systems (DAS) are purchased off-the-shelf. The Davis weather pro has gained popularity among institutions all over the country. The Nigerian Meteorological Agency (NiMET) and the Tropospheric Data Acquisition Network (TRODAN) are the central data repository agencies in the country, where almost all students, data scientists and analysts obtain data for any region of interest in the country [1]-[2]. The TRODAN acquires atmospheric data using the Campbell Scientific automatic Weather Station equipment [2]. Occasionally a researcher may face difficulty obtaining data from these agencies because of the long-distance of the repository from the researcher's station, inconveniences, cost of data purchase, requisition protocol and bureaucracy. Usually, the servicing of this equipment is few and far between, and as such, some data retrieved are either missing with their dates skipped or unreliable, probably caused by natural or artificial noise interference. Also, the desired parameter may not even be captured. For example, hardly one finds the record of soil temperature in most DASs [3]-[8], which is essential to the local farmer.

Many DAS have been developed to measure and process meteorological data using different approaches. Numerous microprocessor/microcontroller-based data acquisition systems for solar energy and environmental monitoring are available commercially and in literature [3]-[8]. A few attractive



software and development tool kits available commercially are Wasmote (with more than 110 sensors) from Libelium [9], MSP430 launchpad from Texas instruments, STML series ST Microelectronics, the Raspberry Pi (with other 'fruit' Pi) [10], and the Arduino [11]. All with their attendant and unique flash memory, frequencies, RAM, data EPROM and power consumption ratings. Development kits are either microcontroller-based kits or multi-component single-board computer with a microprocessor. Many DAS designs used Microchip's PIC16F877 microcontroller [12]-[19]. The PIC16F877 includes an onboard interface design and analog-to-digital converter with an onboard DS18B20 temperature sensor at low cost and high reliability.

Also, some DAS employed the Arduino development kit, which has the ATmega328 or 2560 as the base microcontroller [5],[6],[13],[20]. Contrary to PIC-based systems, where a separate A/D converter was interfaced to the PIC16F877 unit to record a set of sensors' signals and the data stored in a local EPROM, the Arduino has both the A/D converter and EPROM embedded. Hence the Arduino became a fitting choice because it is a more user-friendly hardware platform with software coding called a 'Sketch'. The sketch is the Arduino open-source, proprietary integrated development environment (IDE) platform. The Arduino IDE offers an exceedingly cost-effective solution to a wide range of applications since it contains accessible software found in the library. The platform's popularity has increased markedly over the years because of the flexibility of the open-source IDE – easily obtainable example or tutorial sketches uploaded online by hobbyists, science and engineering contributors - that enable complex electrical and engineering systems development. These attributes attract hobbyists, researchers and system developers to applying the Arduino open-source IDE as a microcontroller-based data acquisition system. The board consists of general-purpose I/O pins, USB programming and I2C and SPI communication interfaces, voltage regulator and power input connections, Debugging, Rx and Tx LEDs and in-circuit serial programming connectors. More literature on Arduino is available from the developer's website [6],[11]. There is a proliferation of Arduino-based data logger designs that are accessible online. Compatible peripheral sensor modules or 'shields' are also readily available in the market. The board is a reasonably priced complete stand-alone microcontroller, e.g., the ATmega328 for the Uno/Nano or ATmega2560 for the Mega. In this work, the Arduino Mega 2560 was used as the main microcontroller because of its more general input/outputs (54) and analog-to-digital converter (ADC) channels, which allow for interfacing with input sensors, than the Uno. The DAS is one of the numerous efforts toward improving communication systems in line with the sustainable development goal (SDG) 13 – climate action.

2. Materials and methods

2.1. Basic Block Diagram of DAS

Figure 1 is the building block diagram of the developed Data Acquisition System. It consists of sensors for atmospheric temperature, pressure, relative humidity, three soil temperature sensors, ultraviolet, rainfall and a wind speed sensor. It also consists of signal conditioning circuits, analog-to digital converters (ADC), real-time clock module, SD card shield for data logging, LCD unit, microcontroller and power supply unit using battery and solar panel.

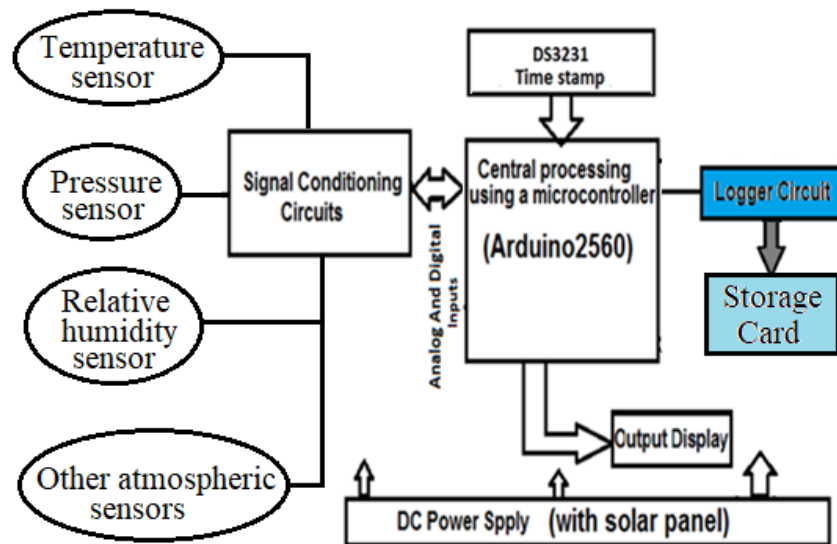

Figure 1 Block diagram of the developed DAS system.

2.2. Design and Fabrication of Sensors

The DS18B20, a digital temperature sensor, was wired as an air-temperature sensor and placed in a fabricated Stevenson screen. It has a resolution range of 9-bits to 12-bits in steps of 0.5 °C down to 0.0625 °C. The DS18B20 was sealed to prevent water from penetrating the sensor. The Honeywell HIH-4030 was used as the humidity sensor. It uses a laser trimmed, thermoset polymer capacitive sensing element with on-chip integrated signal conditioning. The ML8511 was employed as an ultraviolet radiation sensor for the index level within the UV-A and UV-B range. A three-cup type wind speed sensor with an output voltage range from 0-5 V was wired into the Arduino based DAS. Similarly, the MPXA6115A sensor, a piezo-resistive transducer for pressure measurements, was used to measure the atmospheric pressure. This integrated circuit, MPXA6115A, is manufactured by Motorola, and it requires a power supply of 5 V with an output range between 0 and 5 V for pressure values between 15 kPa to 115 kPa (or 150 mbar to 1150 mbar).

2.3. Complete Circuit Description of the Developed DAS

The developed DAS system consists of the main microcontroller, Arduino Mega2560, that controls all the activities within the system. The complete circuit of the DAS system is shown in Figure 2. Wind speed and ultraviolet radiation sensors were connected to the Arduino's ADC input with the address of A0 and A1 pins. The air temperature sensor's output uses serial communication, a one-wire connection. It was connected to digital input and output pin D22. The data storage medium is connected to the I2C communication link on the Arduino. The SD card memory points MOSI, MISO, CS and SCK were connected to digital pins D50, D51, D52 and D53, respectively. The LCD was driven using a serial communication link to the microcontroller through PD7, PD6, PD5, PD4, including pins E and R/W and other data pins.

2.4. Weather Instrument Shelter

A weather instrument shelter is also known as Stevenson Screen. It is a big box painted white to reflect the sun's rays and, most time, made of wood with a louvred side that allows proper air circulation within the box. The Stevenson Screen houses and protects weather instruments and sensors from direct solar radiation, precipitation and animals. It was placed at least one meter above the ground level to prevent thermometers and other instruments' erroneous readings due to heat conduction from the ground. For this study, the microcontroller, signal conditioning circuits, data logger and power supply circuits were placed adequately inside a Stevenson screen measuring 30 x 18 x 40 cm with half-front transparent plastic shown in Figure 3.

3. Results

The temperature, UV, humidity and wind speed sensors were tested, compared with the off-the-shelf sensors and the results were presented. DS18B20 and HIH4030 sensors were compared with mercury-in-glass and dry and wet thermometers for air temperature and relative humidity performance, respectively, in Figures 4a and 4b. Similarly, the daily variation of temperature measured by the DAS was compared with that of the nearby station, Osogbo, in Figure 5b. Also, the daily values of the ultraviolet (UV) radiation were compared with the UV data from Osogbo in Figure 6.

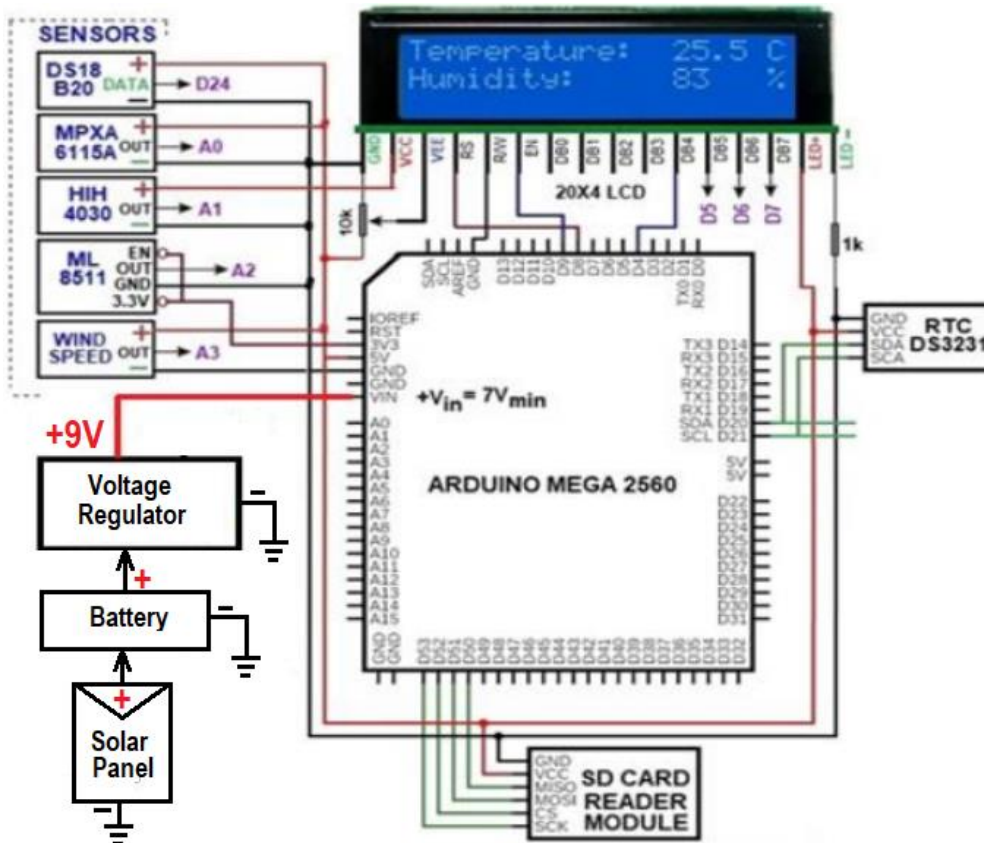

Figure 2 The complete schematic diagram of the developed DAS system.

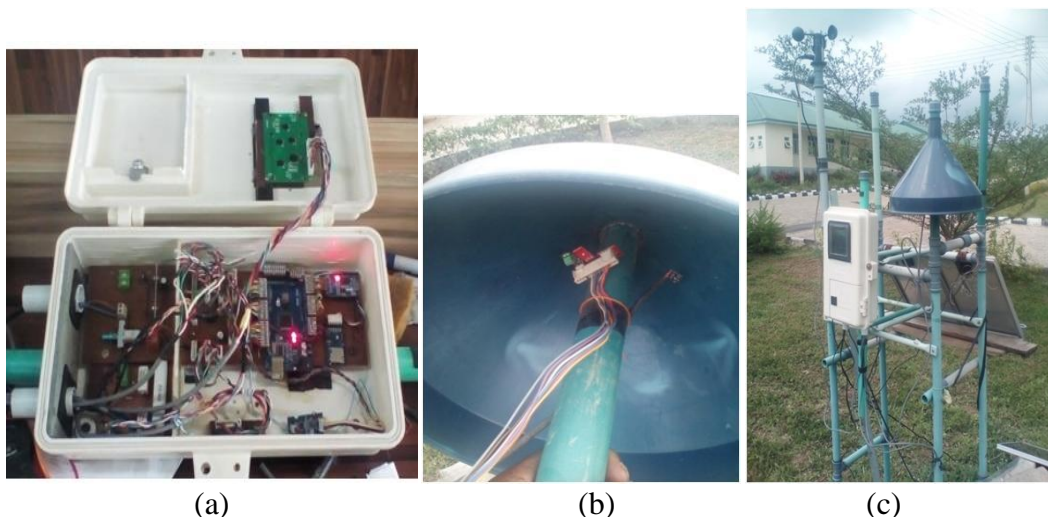

Figure 3 Housing of the (a) DAS system, (b) atmospheric sensors and (c) the final installation.

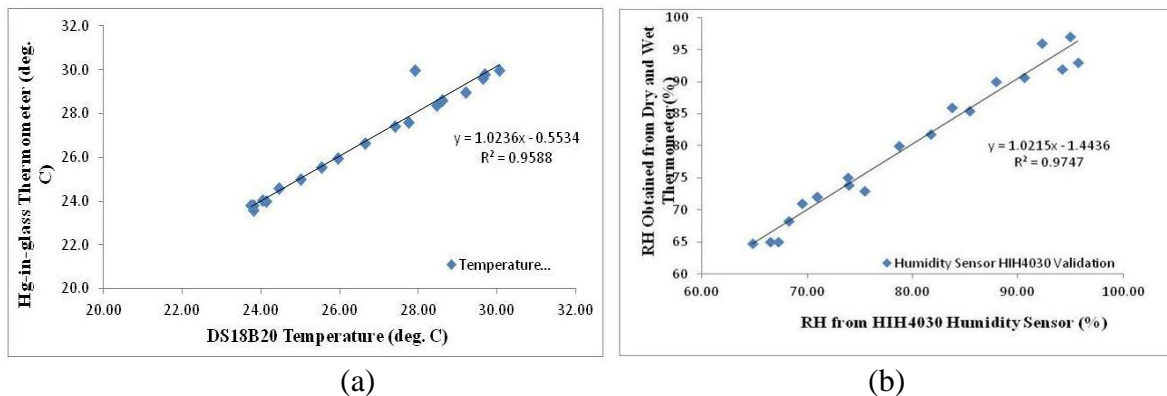

Figure 4 Comparison of (a) DS18B20 with Hg-in-glass thermometer (b) HIH4030 with relative humidity (RH) obtained from a wet-and-dry-bulb thermometer.

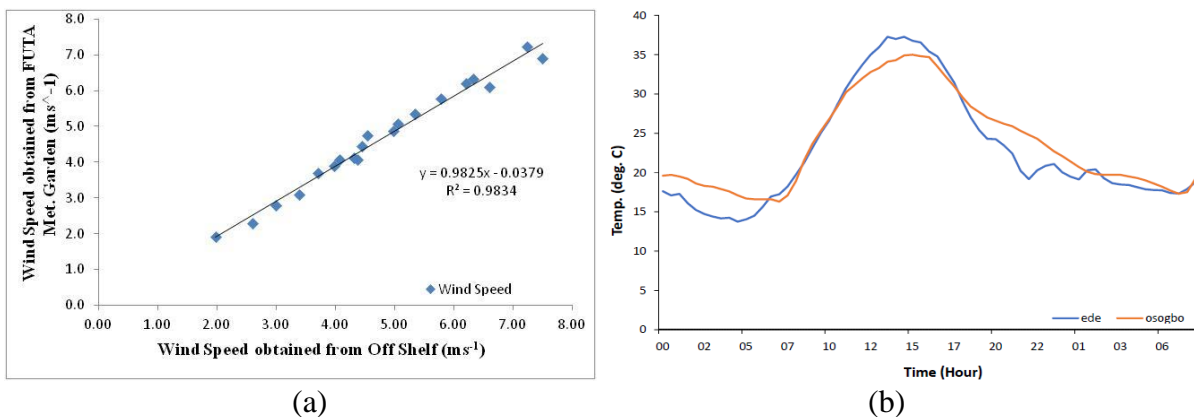

Figure 5 Comparison of (a) Off-the-Shelf wind speed device with Campbell wind speed device, and (b) daily variation of air temperature at Ede (blue) and Osogbo (red) for January 2020 and January 2017, respectively.

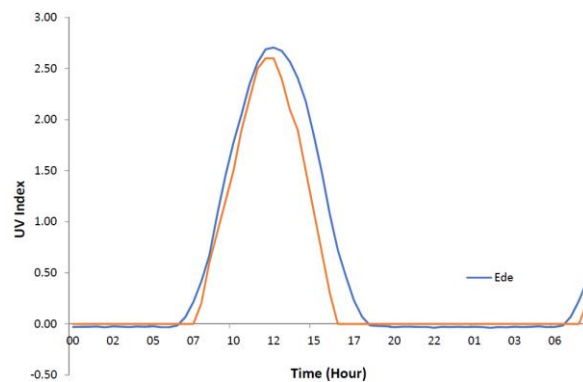

Figure 6 Comparison of daily variation of UV index at Ede (blue) and Osogbo (red) for January 2020 and January 2017, respectively.

According to Figures 4 and 5a, the correlation coefficients of mercury-in-glass thermometer and DS18B20 temperature sensor, and dry-and-wet-bulb thermometer and HIH4030 RH sensor were 0.9588 and 0.9747, respectively. Similarly, the wind speed data from the Davies instrument installed at the Federal University of Technology, Akure (FUTA) and those of the off-the-shelf wind speed sensor agreed with a correlation coefficient of 0.9834. Figures 5b and 6 showed that the DAS's air temperature

and ultraviolet measurements followed the same trend with the data collected from a nearby station at Osogbo.

The derived parameters namely atmospheric radio refractive index, n , radio refractivity, N (N-units), surface radio refractivity, N_s (N-units) [1], were obtained from equations (1) – (6)

$$n = 1 + N \times 10^{-6} \tag{1}$$

$$N = 77.6 \frac{P}{T} + 3.73 \times 10^5 \frac{e}{T^2} \tag{2}$$

$$e = e_s \times RH \times 0.01 \tag{3}$$

$$e_s = 6.11 \times 10^{\frac{at}{t+b}} \tag{4}$$

$$N_s = N_0 \exp\left(-\frac{h}{H}\right) \tag{5}$$

$$-\Delta N = A \exp(BN_s) \tag{6}$$

where P = atmospheric pressure, (hPa), e = water vapour pressure, (hPa), T = absolute temperature (K), e_s = saturated water vapour pressure, RH = relative humidity (%), $a = 7.5$, $b = 237.3$ and t = temperature ($^{\circ}\text{C}$), N_0 = average value of atmospheric refractivity reduced to sea level, h = height of the Earth's surface above sea level (in km) for $h = 0.1$ km, 1 km 2 km, 4 km, 6 km, 10 km, H = scale height (in km) $A = 9.36$, $B = 4.856 \times 10^{-3}$ for Nigeria [21], and $A = 2.30$, $B = 8.63 \times 10^{-3}$ for Africa [22].

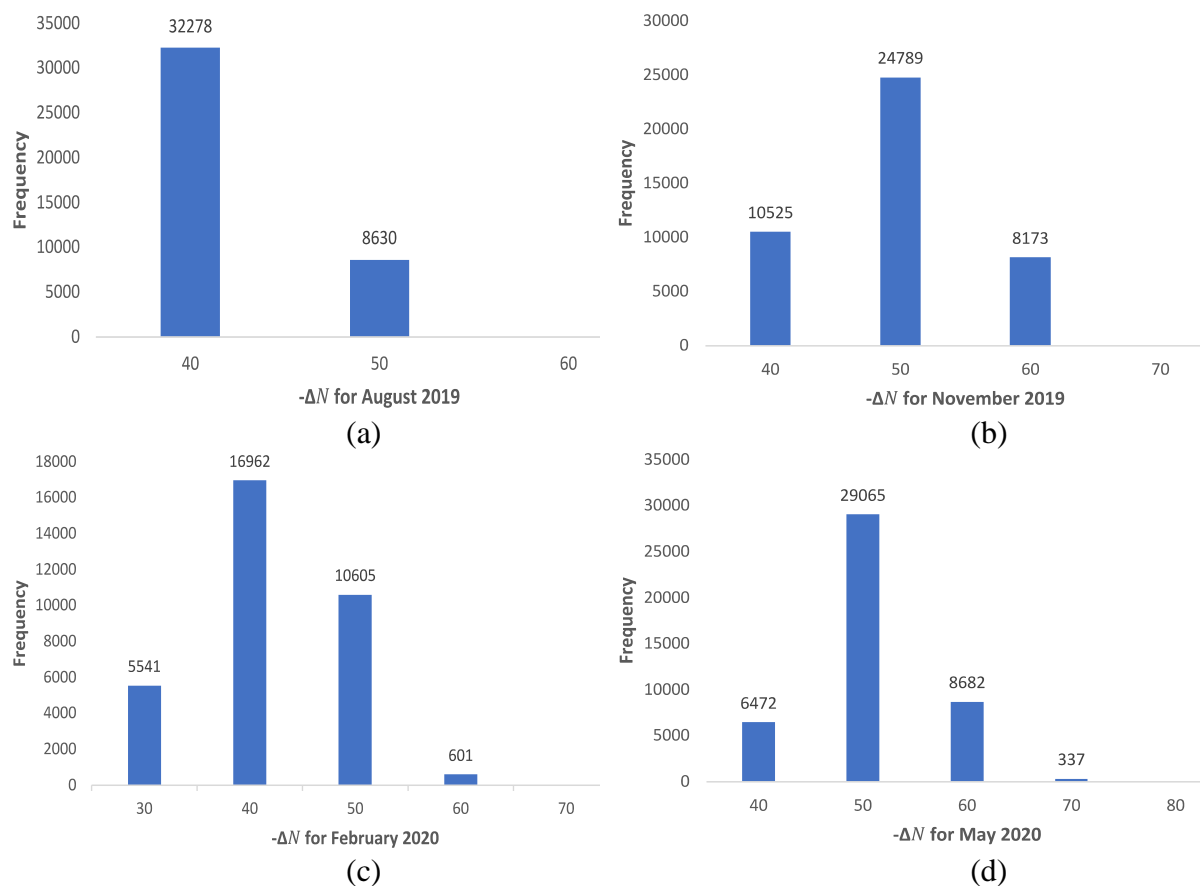

Figure 7 Radio refractivity gradients, $-\Delta N$ (N-units/km), distribution in (a) August 2019, (b) November 2019, (c) February 2020 and (d) May 2020.

Figure 7 reveals the dominant refractivity gradients for the months under consideration, which could be used to characterize the prevailing radio refractive conditions over Ede. The knowledge of these atmospheric conditions is vital for both radio engineers and radio scientists.

4. Conclusion

The development of a weather monitoring system based on the Arduino microcontroller board has been presented. The data acquisition system (DAS) used both locally developed low-cost and off-the-shelf sensors with high accuracy, good precision, high sensitivity and good response time for the weather monitoring system. The DAS has been tested and examined through intensive experimental work. The preliminary plots obtained from the study agreed with the data collected from the existing calibrated systems. The DAS will help monitor atmospheric parameters. The need for extra cost baud rate and expensive third-party software for interfacing to download data from the logger has been eliminated. Internet connection is not required to set up and configure the DAS. It is therefore evident that the DAS could be a better choice in terms of cost and maintenance. The developed DAS system would help estimate daily, diurnal, monthly and seasonal variations of tropospheric radio refractivity with higher accuracy for the climatic conditions over Ede, Osun State, Nigeria. The system applies to regions of similar climatic information. Hence the DAS will provide valuable data for radio meteorology and other allied applications.

References

- [1] Dairo O F and Kolawole L B 2018 Radio refractivity gradients in the lowest 100 m of the atmosphere over Lagos, Nigeria in the rainy-harmattan transition phase *J. Atmos. Sol.-Terr. Phys.* **167** 169-176 <https://doi.org/10.1016/j.jastp.2017.12.001>.
- [2] Dairo O F, Willoughby A A, Adesanya S O and Kolawole L B 2020 Tropospheric scintillation effects on satellite links from X-band to Q-band over Nigerian climatic zones using Karasawa and ITU-R models *Telecommun. Radio Eng.* **79** 1 1-16 <https://doi.org/10.1615/TelecomRadEng.v79.i1.10>.
- [3] Mukaro R and Carelse X F 1999 A microcontroller-based data acquisition system for solar radiation and environmental monitoring *IEEE Trans. Instrum. Meas.* **48** 6 1232-38 <https://doi.org/10.1109/19.816142>.
- [4] Koutroulis E and Kalaitzakis K 2003 Development of an integrated data-acquisition system for renewable energy sources systems monitoring *Renew. Energy* **28** 1 139-152 [https://doi.org/10.1016/s0960-1481\(01\)00197-5](https://doi.org/10.1016/s0960-1481(01)00197-5).
- [5] Rosiek S and Batlles F J 2008 A microcontroller-based data-acquisition system for meteorological station monitoring *Energy Convers. Manag.* **49** 12 3746-54. <https://doi.org/10.1016/j.enconman.2008.05.029>
- [6] Fuentes M, Vivar M, Burgos J M, Aguilera J and Vacas J A 2014 Design of an accurate, low-cost autonomous data logger for PV system monitoring using Arduino™ that complies with IEC standards *Sol. Energy Mater. Sol. Cell.* **130** 529-543 <https://doi.org/10.1016/j.solmat.2014.08.008>.
- [7] Gad H E and Gad H E 2015 Development of a new temperature data acquisition system for solar energy applications *Renew. energy*, **74** 337-343 <https://doi.org/10.1016/j.renene.2014.08.006>.
- [8] Rezk H, Tyukhov I and Raupov A 2015 Experimental implementation of meteorological data and photovoltaic solar radiation monitoring system *Int. Trans. Electr. Energy Syst.* **25** 3573-85 <https://doi.org/10.1002/etep.2053>.
- [9] www.libelium.com/product/waspmote
- [10] www.raspberrypi.org
- [11] www.arduino.cc
- [12] Benganem M 2001 A low-cost wireless data acquisition system for weather station monitoring *Renew. Energy* **35** 4 862-872 <https://doi.org/10.1016/j.renene.2009.08.024>.
- [13] Ameer S, Laghrouche M and Adane A 2001 Monitoring a greenhouse using a microcontroller-based meteorological data-acquisition system *Renew. Energy* **24** 1 19-30 [https://doi.org/10.1016/s0960-1481\(00\)00181-6](https://doi.org/10.1016/s0960-1481(00)00181-6).
- [14] Abidin A F, Jusoh M H, James E, Al Junid S A and Mohd Yassin A I 2015 Real-Time Remote Monitoring with Data Acquisition System, *IOP Conf. Ser.: Mater. Sci. Eng.* **99** 012011 <https://doi.org/10.1088/1757-899x/99/1/012011>.
- [15] Bencúr A and Kašík V 2004 C07: Compact data acquisition module for the applications of meteorological measurements *IFAC Proc. Vol.* **37** 20 pp 299-303.
- [16] Ghosh M, Ghosh S, Saha P and Panda G 2016 Design and Implementation of PIC16F877A Microcontroller Based Data Acquisition System with Visual Basic Based GUI, *7th Int. Conf. on Intelligent System Modelling and Simulation (ISMS)* 2016 pp 419-423 <https://doi.org/10.1109/isms.2016.32>.

- [17] Ang L-M and Seng K P 2016 Big Sensor Data Applications in Urban Environments *Big Data Res.* **4** 1-12 <https://doi.org/10.1016/j.bdr.2015.12.003>.
- [18] Castro A, Martínez-Osuna J F, Michel R, Escoto-Rodríguez M, Bullock S H, Cueva A and Vargas R 2017 A low-cost modular data-acquisition system for monitoring biometeorological variables *Comput. Electron. Agric.* **141** 357-371 <https://doi.org/10.1016/j.compag.2017.08.010>.
- [19] Hongmin W, Zhue J, Xufei N and Dandan L 2012 Design of PIC microcontroller-based high-capacity multi-channel data acquisition module *Proc. of Int. Conf. on Measurement, Information and Control* 2012 pp 685-688 <https://doi.org/10.1109/mic.2012.6273385>.
- [20] Mukaro R, Carelse X and Olumekor L 1998 First performance analysis of a silicon-cell microcontroller-based solar radiation monitoring system *Sol. Energy* **63** 5 313-321 [https://doi.org/10.1016/s0038-092x\(98\)00072-3](https://doi.org/10.1016/s0038-092x(98)00072-3).
- [21] Willoughby A A, Aro T O and Owolabi I E 2002 Seasonal variations of radio refractivity gradients in Nigeria, *J. Atmos. Sol.-Terr. Phys.* **64** 4 417-425 [https://doi.org/10.1016/S1364-6826\(01\)00111-0](https://doi.org/10.1016/S1364-6826(01)00111-0).
- [22] Kolawole L B 1983 Statistics of radio refractivity and atmospheric attenuations in tropical climates (Africa) *Wave propagation and remote sensing. Proc. URSI Commission F symp.* 1983 Louvain-la-Neuve, Belgium pp 69-75.